

# POWERLIGHT

## Air Driven Lamp **Industrial Equipment**

### MODEL BH80L



The product could work under the Ambient temperature from  $-20^{\circ}\text{C}$  to  $+50^{\circ}\text{C}$ , ambient compressor air 80kPa-110kPa. It is apply to flammable powder area which is Zone 1 and Zone 2; Zone 21 and Zone 22 of II class, apply to gas area of II A, II B, II C class. Temperature classification is from T1 to T6 explosion. We have got the explosion-proof certificate from the nation's inspection laboratory. It could be used in flammable and explosion area such as mines, petroleum enterprises, marines, gas stations, oil pump workshop, freight station and so on. Explosion-proof mark: Exs II T4/DIPA21 TA, T4.

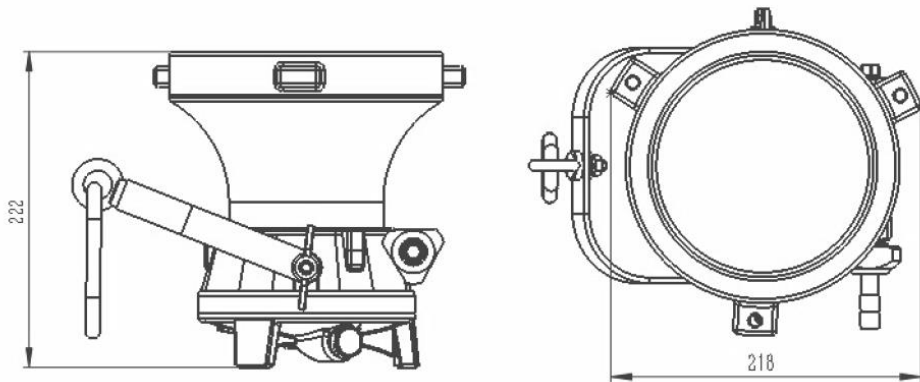

Name	Item	Volt	Watt and light source	Weight	Classification	Consumption
Explosion proof air driven lamp	BH80L	24 Volt	84 Watt LED (8000 Lm)	13.5 kg	IP67 when work IP40 when not work	$<0.75\text{m}^3/\text{min}$ (0.4-0.8 Mpa)